

DNP/5280 Revision 1.1 – User Information

The DIL/NetPC DNP/5280 provides a very compact ColdFire-based low power embedded controller (Motorola 32-bit MCF5280) with TCP/IP stack and Web server for high-speed embedded networking applications. The main features are:

- ColdFire Microcontroller MCF5280 with 66 MHz Clock Speed
- 128 Mbit (16 Mbytes) SDRAM MT48LC4M32B2 with 32-bit Data Bus
- 64 Mbit (8 Mbytes) Flash Am29LV640 with 16-bit Data Bus
- 10/100 Mbps Ethernet PHY RTL8201 (25 MHz Clock Source)

The DIL/NetPC offers the footprint of a standard 64-pin DIL socket with 2.54mm centers and all the hardware and software features necessary to add high-speed networking capabilities to any product design. The DIL/NetPC is developed specifically for products that need to be connected to 10 or 100 Mbps Ethernet-based TCP/IP networks with minimum development costs.



Figure 1: The DIL/NetPC DNP/5280 with a ColdFire MCF5280 Microcontroller

The DIL/NetPC DNP/5280 is a ready-to-run full programmable 32-bit embedded networking system. The use of the DNP/5280 will allow you to realize substantial time and costs savings over other chip-based approaches. Currently, there is no other 10/100 Mbps Ethernet- and TCP/IP-based embedded networking solution with more development time savings on the market. There is also no faster Time-to-Market for your product with lower costs if 32-bit-based 10/100 Mbps Ethernet, full TCP/IP and a embedded Web server or other TCP/IP-based server software is required.

To interface the DNP/5280 with existing devices and equipment, the DNP/5280

offers two asynchronous serial RS232C interfaces with TTL levels and handshake signals, I2C interchip bus interface, queued SPI (Serial Peripheral Interface), CAN interface with support for the CAN protocol specification 2.0B, 20-bit general purpose high-speed parallel I/Os and a 8-bit extension bus with interrupt inputs and chip select outputs.

There are two ways for DNP/5280 integration: 1. Adapt the DNP/5280 to your existing product. Use the existing I/Os within your product to communicate with the DNP/5280. 2. Use the DNP/5280 to control and monitor the hardware of your existing product. This might enable you to replace your existing controller entirely. In a new product design, the DNP/5280 can be the main controller. Additional I/Os are driven by the 8-bit extension bus.

The Motorola ColdFire MCF5280 Microcontroller

The MCF5282 is the first microcontroller based on Motorola's 32-bit ColdFire core integrated with Ethernet, Flash and CAN. This device offers advanced communications features, a rich peripheral set and a variety of supporting software and development tools.

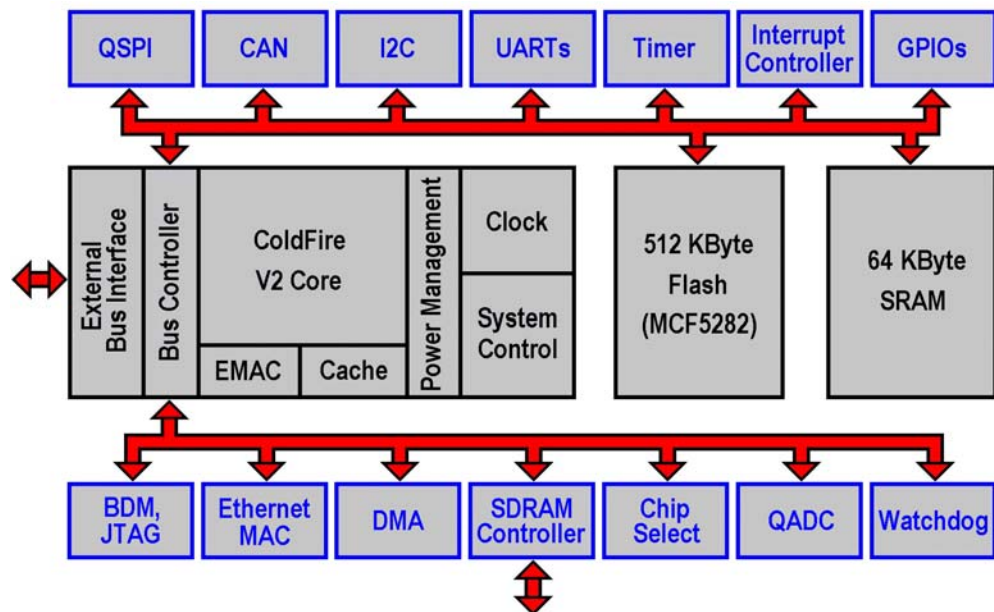

Figure 2: MCF5280/MCF5282 Block Diagram

The MCF5282 is designed to simplify embedded Ethernet-networked microcontroller applications. With its integrated 10/100 Mbps Ethernet MAC and network-ready applications software, the MCF5282 can bring standards-based networking to a variety of traditional MCU applications including food service equipment, security systems, vending machines, exercise equipment and industrial controllers. Applications in all of these areas will benefit from networking functions such as Web-based user interfaces, network time synchronization, and router/gateway functionality for legacy serial protocols. The MCF5282 main features are:

- V2 ColdFire core delivering 54 (Dhrystone 2.1) MIPS at 66 MHz running from internal Flash (max from Cache/RAM 63 MIPS)
- 512KB embedded Flash memory (only the MCF5282, not the MCF5280)
- Enhanced Multiply-Accumulate Unit (eMAC) for DSP functionality
- 64 Kbytes of static RAM
- 10/100 Ethernet MAC
- Cache for external access support
- Address decode and chip selects

- CAN 2.0B controller area network interface with 16 message buffers
- Three UARTs with DMA capability
- Queued serial peripheral interface (QSPI) with four peripheral chip selects
- 8-channel 10-bit queued analog-to-digital converter (QADC)
- Four 32-bit timers with capture, compare and DMA capability
- Eight 16-bit timer channels for capture, compare, and pulse width modulation
- Four periodic interrupt timers (PITs)
- I2C bus controller
- JTAG for board testing
- BDM for debug, including real-time trace
- 17 mm x 17 mm x 1.6 mm 256-ball MAPBGA package
- Operation at 66 MHz from -40C to +85C

Some MCF528x feature are not accessible with the DIL/NetPC DNP/5280. The main reason for that is the DIL-64 connector and the pin-out compatibility to other DIL/NetPCs with DIL-64 connectors.

The DIL/NetPC DNP/5280 Block Diagram

The DIL/NetPC DNP/5280 is build around Motorola's 32-bit ColdFire MCF5280/MCF5282 microcontroller unit (MCU) running with 66 MHz. The external main components around the ColdFire are one Flash memory chip with 8 Mbytes, one 16-MByte SDRAM memory chip, and one 10/100 Mbps Ethernet PHY (the Ethernet MAC is a part of the ColdFire MCU).

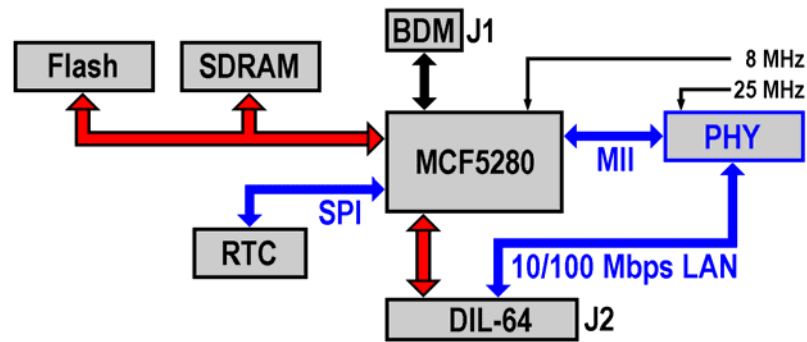

Figure 3: DIL/NetPC DNP/5280 Block Diagram

The DIL/NetPC DNP/5280 LAN interface is equipped with four small on-board LEDs. Table 1 offers a overview.

Name	Function	
LED0	Link	Ethernet Cable Connection available
LED1	Duplex	Duplex Mode
LED2	10Act	10 Mbps LAN Traffic
LED3	100Act	100 Mbps LAN Traffic

Table 1: DNP/5280 LAN LEDs

The 66 MHz clock speed of the DIL/NetPC DNP/5280 comes from a 8 MHz clock source.

The DNP/5280 offers only two connectors: J1 (BDM Interface) and J2 (64-pin DIL Connector). Table 2 and Table 4 of this document show the pinout.

Pinout J1: BDM Connector (J0501)

Pin	Name	Remarks
1	VIO (3.3 VDC I/O Voltage)	
2	GND	
3	TA#	BDM Function
4	BKPT#	BDM Function
5	Reset#	BDM Function
6	DSCLK#	BDM Function
7	DSI#	BDM Function
8	TCLK	BDM Function
9	PST3	BDM Function
10	DS0	BDM Function
11	PST2	BDM Function
12	DDATA3	BDM Function
13	PST1	BDM Function
14	DDATA2	BDM Function
15	PST0	BDM Function
16	DDATA1	BDM Function
17	PSTCLK	BDM Function
18	DDATA0	BDM Function
19	GND	
20	RCM	GPTB3

Table 2: J1 Pinout (DNP/5280 BDM Connector)

Please note: Pin 20 (RCM = Remote Console Mode) of connector J1 is a jumper position point. The DNP/5280 allows you to connect this pin with the help of a small 2 mm jumper bridge to pin 19 (GND) of connector J1.

RCM is direct connected to pin T12 (GPTB3) of the Motorola 32-bit ColdFire MCF5280/MCF5282 microcontroller. There is also a 4700 Ohms resistor to 3.3 VDC on-board for pulling GPTB3 to Vcc (GPTB3 = 1) if no jumper bridge available.

Pin 19 – Pin 20	Status
Jumper not available	GPTB3 = 1 (High)
Jumper available	GPTB3 = 0 (Low)

Table 3: The RCM Jumper Modes

The DNP/5280 default boot loader and ROM monitor program *dBUG* checks RCM at power-up. If no jumper bridge is available (GPTB3 = 1), *dBUG* is running the uClinux image from Flash memory. If *dBUG* detects a jumper bridge from pin 19 to pin 20, this program enters a command mode.

Pinout J2: DIL-64 Connector (J0901)

Pin	Name	Function
1	PA0	Parallel I/O, Port A, Bit 0
2	PA1	Parallel I/O, Port A, Bit 1
3	PA2	Parallel I/O, Port A, Bit 2
4	PA3	Parallel I/O, Port A, Bit 3
5	PA4	Parallel I/O, Port A, Bit 4
6	PA5	Parallel I/O, Port A, Bit 5
7	PA6	Parallel I/O, Port A, Bit 6
8	PA7	Parallel I/O, Port A, Bit 7
9	PB0	Parallel I/O, Port B, Bit 0
10	PB1	Parallel I/O, Port B, Bit 1
11	PB2	Parallel I/O, Port B, Bit 2
12	PB3	Parallel I/O, Port B, Bit 3
13	PB4	Parallel I/O, Port B, Bit 4
14	PB5	Parallel I/O, Port B, Bit 5
15	PB6	Parallel I/O, Port B, Bit 6
16	PB7	Parallel I/O, Port B, Bit 7
17	PC0	Parallel I/O, Port C, Bit 0
18	PC1	Parallel I/O, Port C, Bit 1
19	PC2	Parallel I/O, Port C, Bit 2
20	PC3	Parallel I/O, Port C, Bit 3
21	RXD1	COM1 Serial Port, RXD Pin
22	TXD1	COM1 Serial Port, TXD Pin
23	CTS1	COM1 Serial Port, CTS Pin
24	RTS1	COM1 Serial Port, RTS Pin
25	DCD1	COM1 Serial Port, DCD Pin
26	DSR1	COM1 Serial Port, DSR Pin
27	DTR1	COM1 Serial Port, DTR Pin
28	RI1	COM1 Serial Port, RI Pin
29	RESIN	RESET Input
30	TX+	10/100 Mbps LAN, TX+ Pin
31	TX-	10/100 Mbps LAN, TX- Pin
32	GND	Ground

Table 4.A: J2 Pins 1 to 32

Pin	Name	Function
33	RX+	10/100 Mbps LAN, RX+ Pin
34	RX-	10/100 Mbps LAN, RX- Pin
35	RESOUT	RESET Output
36	VBAT	Real-Time Clock Battery
37	CLKOUT	Clock Output
38	TXD2	COM2 Serial Port, TXD Pin
39	RXD2	COM2 Serial Port, RXD Pin
40	INT5	Interrupt Input 5
41	INT4	Interrupt Input 4
42	INT3	Interrupt Input 3
43	INT2	Interrupt Input 2
44	INT1	Interrupt Input 1
45	CS4	Chip Select Output 4
46	CS3	Chip Select Output 3
47	CS2	Chip Select Output 2
48	CS1	Chip Select Output 1
49	IOCHRDY	I/O Channel Ready
50	IOR	I/O Read Signal
51	IOW	I/O Write Signal
52	SA3	Address Bit 3
53	SA2	Address Bit 2
54	SA1	Address Bit 1
55	SA0	Address Bit 0
56	SD7	Data Bit 7
57	SD6	Data Bit 6
58	SD5	Data Bit 5
59	SD4	Data Bit 4
60	SD3	Data Bit 3
61	SD2	Data Bit 2
62	SD1	Data Bit 1
63	SD0	Data Bit 0
64	VCC	3.3 Volt Power Input

Table 4.B: J2 Pins 33 to 64

Function Multiplexing of the DIL-64 Connector

Some pins at the DIL/NetPC DNP/5280 DIL-64 connector J2 are multifunction pins with a primary function and a secondary function. The default use is identical to the primary function.

Pin	Name	Primary Function	Secondary Function
13	PB4	Parallel I/O, Port B, Bit 4	SCL (I2C)
14	PB5	Parallel I/O, Port B, Bit 5	SDA (I2C)
15	PB6	Parallel I/O, Port B, Bit 6	CANTX (CAN)
16	PB7	Parallel I/O, Port B, Bit 7	CANRX (CAN)
17	PC0	Parallel I/O, Port C, Bit 0	QSPIDO (SPI)
18	PC1	Parallel I/O, Port C, Bit 1	QSPIDI (SPI)
19	PC2	Parallel I/O, Port C, Bit 2	QSPICLK (SPI)
20	PC3	Parallel I/O, Port C, Bit 3	QSPICS0 (SPI)

Table 5: Multifunction Pins of the DNP/5280 DIL-64 Connector

The primary function of the pins shown at Table 5 is identical to the DIL/NetPC DIL-64 standard pinout. This pin functions are compatible to other DIL/NetPCs with DIL-64 connectors. The secondary functions are ColdFire-specific.

PIO Pin Mapping

The bits of the DNP/5280 20-bit PIO (Parallel Input Output Port) are directly connected to signals of the Motorola MCF5280 ColdFire 32-bit microcontroller. The following table shows this mapping. Please see also the *MCF5282 ColdFire Microcontroller User's Manual R.0.1* (MCF5282UM/D) for the MCF5280 pin function details.

Pin	Name	MCF5280 Pin Function	MCF5280 Pin
1	PA0	AN52	R4
2	PA1	AN53	T4
3	PA2	AN55	P3
4	PA3	AN56	R3
5	PA4	AN0	T3
6	PA5	AN1	R2
7	PA6	AN2	T2
8	PA7	AN3	R1
9	PB0	GPTA0	N13
10	PB1	GPTA1	P13
11	PB2	GPTA2	R13
12	PB3	GPTA3	T13
13	PB4	SCL	E15
14	PB5	SDA	E14
15	PB6	CANTX	E13
16	PB7	CANRX	D16
17	PC0	QSPIDO	F13
18	PC1	QSPIDI	E16
19	PC2	QSPICLK	F14
20	PC3	QSPICS0	F15

Table 6: DNP/5280 PIO Pin Mapping to MCF5280 Pins

COM Port Pin Mapping

The 10 pins of the two DIL/NetPC DNP/5280 UARTs (Serial Ports COM1 and COM2) are direct connected to signals of the Motorola MCF5280 ColdFire 32-bit microcontroller. The following table shows this mapping.

Pin	Name	MCF5280 Pin Funktion	MCF5280 Pin	Source
21	RXD1	URXD0	N6	UART
22	TXD1	UTXD0	T7	UART
23	CTS1	DTOUT0	J13	UART
24	RTS1	DTOUT1	J15	UART
25	DCD1	DTOUT2	K13	GPIO
26	DSR1	DTIN2	K14	GPIO
27	DTR1	DTOUT3	K15	GPIO
28	RI1	DTIN3	K16	GPIO
38	TXD2	UTXD1	P7	UART
39	RXD2	URXD1	R7	UART

Table 7: DNP/5280 COM Port Pin Mapping to MCF5280 Pins

Please see also the *MCF5282 ColdFire Microcontroller User's Manual R.0.1* (MCF5282UM/D) for the MCF5280 pin function details.

Bus Signal Mapping (8-bit I/O Expansion Bus)

The 27 pins of the DNP/5280 8-bit I/O Expansion Bus are directly connected to signals of the Motorola MCF5280 ColdFire 32-bit microcontroller. The following table shows this mapping.

Please see also the *MCF5282 ColdFire Microcontroller User's Manual R.0.1* (MCF5282UM/D) for the MCF5280 pin function details.

Pin	Name	MCF5280 Pin Funktion	MCF5280 Pin	Remarks
29	RESIN	RESET	R11	1
35	RESOUT	RSTOUT#	P11	1
37	CLKOUT	CLKOUT	N7	1
40	INT5	IRQ7	B15	
41	INT4	IRQ6	B16	
42	INT3	IRQ5	C14	
43	INT2	IRQ4	C15	
44	INT1	IRQ3	C16	
45	CS4	RAS1#	H13	1
46	CS3	CS3#	L16	
47	CS2	CS2#	L15	
48	CS1	CS1#	L14	
49	IOCHRDY	TA#	P16	
50	IOR	OE#	N16	
51	IOW	R/W#	N15	
52	SA3	A3	E3	
53	SA2	A2	E4	
54	SA1	A1	F1	
55	SA0	A0	F2	
56	SD7	D31	F3	
57	SD6	D30	G1	
58	SD5	D29	G2	
59	SD4	D28	G3	
60	SD3	D27	G4	
61	SD2	D26	H1	
62	SD1	D25	H2	
63	SD0	D24	H3	

Table 8: DNP/5280 Expansion Bus Pin Mapping to MCF5280 Pins

Remark 1: Please see also the Device Errata for the current version of the DNP/5280 within this documentation.

DNP/5280 Memory Mapping

Function Unit	Start Address	End Address	Access Format
SDRAM	0x0000.0000	0x00FF.FFFF	32 Bits
SRAM (intern)	0x2000.0000	0x2000.FFFF	32 Bits
CS1_Space	0x1000.0000	0x100F.FFFF	8 Bits
CS2_Space	0x1010.0000	0x101F.FFFF	8 Bits
CS3_Space	0x1020.0000	0x102F.FFFF	8 Bits
CS4_Space	0x1030.0000	0x103F.FFFF	8 Bits
IBSBAR	0x4000.0000	0x7FFF.FFFF	32 Bits
Flash (MCF5282 intern)	0xF000.0000	0xF007.FFFF	32 Bits
Flash	0xFF80.0000	0xFFFF.FFFF	16 Bits

Table 9: DNP/5280 Memory Mapping

The four memory areas called *CS1_Space* to *CS4_Space* are reserved for the four chip select output pins of the DNP/5280.

The memory area called *IBSBAR* contains the MCF5280 SFRs (Special Function Registers) of the MCF5280 ColdFire MCU.

User programs are located from start address 0x0001:0000 within the DNP/5280 memory space.

DNP/5280 Special Memory Areas

The DIL/NetPC DNP/5280 default boot loader and ROM monitor program *dBUG* is using some memory space within Flash and SDRAM memory.

Function Unit	Start Address	End Address
<i>dBUG</i> ROM Monitor Code Area	0xFF80.0000	0xFF83.FFFF
<i>dBUG</i> ROM Monitor Data Area	0x0000.0000	0x0000.FFFF

Table 10: Reserved Memory Areas for the *dBUG* ROM Monitor

Device Errata

Problem	Remarks
CLKOUT	Pin 37 of the DIL64 Connector. This pin outputs a clock of 66 MHz. Other DIL/NetPCs offers 3.6864 MHz at the same pin. Next version of the DNP/5280 will also offer 3.6864 MHz at pin 37.
CS4	Chip Select CS4, Pin 45 of the DIL64 Connector. This pin is currently unusable. Next version of the DNP/5280 will offer the correct chip select function at pin 45.
LAN	Please ask the SSV Embedded Systems support team for the external components between the DNP/5280 LAN interface a the RJ45 connector.
RTC	The RTC (Real Time Clock) can not be used. Next version of the DNP/5280 will offer a useable RTC.
Supervisor	There is no on-board power supervisor chip available by now. Next version of the DNP/5280 comes with on-board power supervisor chip.

Table 11: Device Errata

Helpful Literature

ColdFire Programmers Reference Manual R.1.0 (MCF5200PRM/AD)
 MCF5282 ColdFire Microcontroller User's Manual R.0.1 (MCF5282UM/D)

Contact

SSV Embedded Systems
 Heisterbergallee 72
 D-30453 Hannover
 Tel. +49-(0)511-40000-0
 Fax. +49-(0)511-40000-40
 E-Mail: sales@ist1.de
 Web: www.ssv-embedded.de
 Web: www.dilnetpc.com

Notes to this Document (5280RelNotes-R112E.Doc)

Revision	Date		Name
1.00	29.08.2003	First Version in German (Rev. 1.00)	KDW
1.10	02.12.2003	Information Update for DNP/5280 Hardware Rev. 1.1	KDW
1.11	21.01.2004	Error Fixing (GPTB3 ./ GPTB2) within Table 2	KDW
1.12	27.01.2004	Translation to English	KDW

© SSV Software Systems GmbH and Klaus-Dieter Walter 1999 – 2004. All rights reserved. No part of this documentation may be copied or reproduced in any form or by any means without the prior written consent of SSV Software Systems GmbH and Klaus-Dieter Walter. Trademarks, brands, or names included in this documentation are for identification purposes only and may be the property of others.

SSV Software Systems GmbH makes no warranty for the use of its products and assumes no responsibility for any errors which may appear in this documents nor does it make a commitment to update the information contained herein. SSV Software Systems GmbH retains the right to make changes to these specifications at any time, without notice. Contact the SSV Software Systems GmbH sales office to obtain the latest specifications before placing your order.