

DIL/NetPC DNP/2486

Board Revision 1.1

Hardware Reference

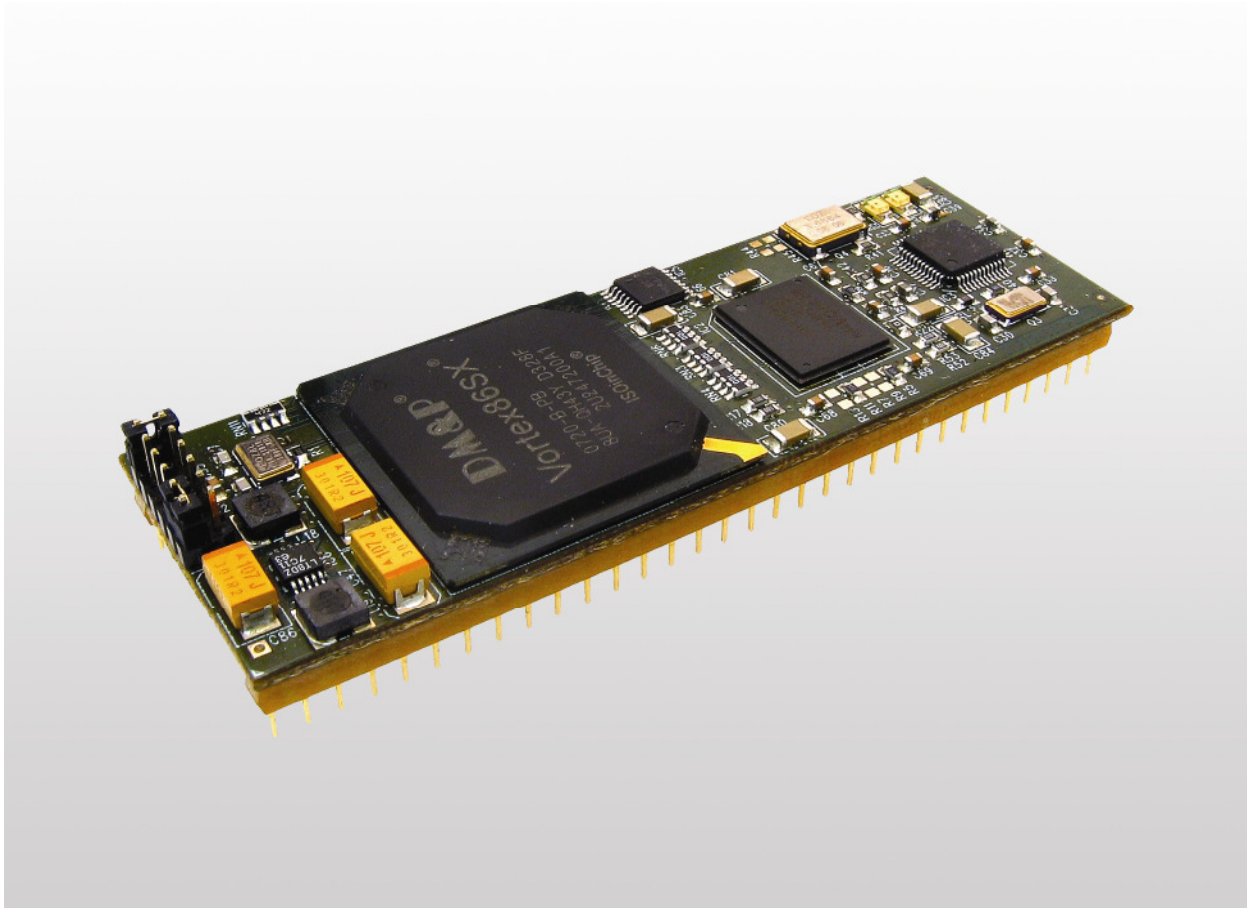

SSV Embedded Systems

Heisterbergallee 72
D-30453 Hannover
Phone: +49 (0)511/40 000-0
Fax: +49 (0)511/40 000-40
E-mail: sales@ist1.de

Document Revision: 1.3
Date: 2009-01-15

CONTENT

- 1 INTRODUCTION3
 - 1.1 Safety Guidelines3
 - 1.2 Conventions3
 - 1.3 Block Diagram4
 - 1.4 Features and Technical Data5
- 2 BOARD LAYOUT6
- 3 PINOUTS7
 - 3.1 DIL-64 Connector – J1 (1. Part)7
 - 3.2 DIL-64 Connector – J1 (2. Part)8
 - 3.3 ISP/Test Connector – J29
 - 3.4 RCM Jumper – JP19
- 4 MEMORY MAP10
 - 4.1 System Memory Map10
 - 4.2 System I/O Map10
- 5 MECHANICAL DIMENSIONS11
- 6 HELPFUL LITERATURE12
- CONTACT12
- DOCUMENT HISTORY12

1 INTRODUCTION

This document describes the hardware components of the DIL/NetPC DNP/2486. For further information about the individual components of this product you may follow the links from our website at <http://www.dilnetpc.com>. Our website contains a lot of technical information, which will be updated in regular periods.

1.1 Safety Guidelines

Please read the following safety guidelines carefully! In case of property or personal damage by not paying attention to this document and/or by incorrect handling, we do not assume liability. In such cases any warranty claim expires.



ATTENTION: Observe precautions for handling – electrostatic sensitive device!

- Discharge yourself before you work with the device, e.g. by touching a heater of metal, to avoid damages.
- Stay grounded while working with the device to avoid damage through electrostatic discharge.

1.2 Conventions

Convention	Usage
bold	Important terms
<i>italic</i>	Filenames, user inputs and command lines
monospace	Pathnames, internet addresses and program code

Table 1: Conventions used in this Document

1.3 Block Diagram

The DIL/NetPC DNP/2486 comes with 1 x 10/100 Mbps Ethernet LAN interface, 20-bit GPIO, 1 x SPI, 2 x UART and 1 x USB 2.0 host port. The 8-bit bus interface (available over the DIL-64 connector) supports the connection to external chips and devices. The main application area of the DNP/2486 is the field of embedded IP gateways for modern industrial and laboratory environments.

The DNP/2486 drive space for the operating system and the user files is implemented with a NAND flash controller and a NAND flash chip. The NAND flash controller is connected to one of the USB 2.0 host controller of the Vortex86SX 32-bit x86 SoC. This means the DNP/2486 is using an on-board USB boot device.

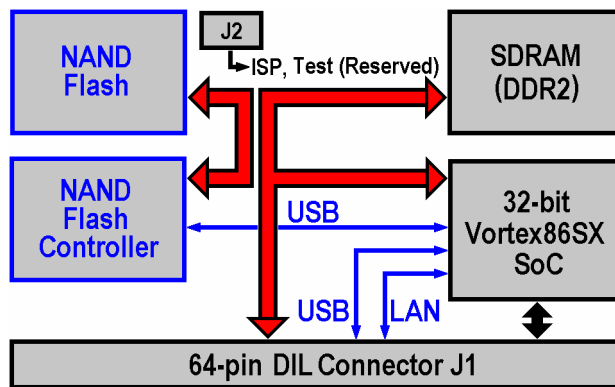

Figure 1: Block diagram of DIL/NetPC DNP/2486

The main component of the DNP/2486 is the Vortex86SX 32-bit x86 SoC (System on Chip). The Vortex86SX is a high performance MCU, which is compatible with DOS, Linux and Microsoft Windows CE. It integrates 32 KB write through direct map L1 cache, PCI Rev. 2.1 32-bit bus interface at 33 MHz, DDR2 SDRAM controller, ROM controller, IPC (Internal Peripheral Controller) with DMA and interrupt timer/counter, Fast Ethernet MAC and PHY, 16C550/16C552-compatible FIFO UART, USB 2.0 Host controller and many more. Please see the Vortex86SX user manuals for more details.

1.4 Features and Technical Data

- Vortex86SX 32-bit x86 SoC with 300 MHz Clock Speed
- PC-compatible AMI Basic I/O System (BIOS)
- 64 MByte SDRAM with DDR2 interface at 133 MHz Bus Speed
- 1 GByte NAND FLASH Memory for O/S Boot Image and Data Files
- 1 x 10/100 Mbps Ethernet LAN Interface
- 1 x USB 2.0 Host Interface with HS, FS and LS support (please see **note 1**)
- 1 x SPI (Serial Peripheral Interface) with one Chip Select Output (please see **note 2**)
- 2 x 16C550/16C552-compatible UART-based Serial Ports (one with all Handshakes)
- 20-bit General Purpose Parallel Port Interface (GPIOs) (please see **note 2**)
- 8-bit I/O Expansion Bus
- 3 Interrupt Inputs, 4 Chip Select Outputs with x86 I/O addresses (please see **note 1**)
- Programmable Watchdog Timer
- 2 x LED for LAN Status and Traffic
- In-System Programming Features
- 64-pin JEDEC DIL-64 Connector, 2.54 mm Centers
- 3.3 Volt Low Power Design, Supply Voltage 3.3 VDC (+- 5%)
- Supply Current 350 mA typ. @ 300 MHz (600 mA max.)
- 0 °C to +70 °C Operating Temperature
- Size 82 mm * 28 mm
- Preinstalled Linux O/S with Kernel Version 2.6.18 or ROM-DOS 6.22 O/S
- RoHS compliant

Note 1: The DNP/2486 USB 2.0 Host Interface is available over the DIL-64 pins 40 & 41. These two pins are normally the interrupt inputs 4 and 5 within the DIL/NetPC DIL-64 pin-out. If your applications needs five interrupt input lines to be compatible with other DIL/NetPCs please contact the SSV sales or technical support staff.

Note 2: The DNP/2486 SPI function uses four pins of the 20-bit General Purpose Parallel Port Interface.

2 BOARD LAYOUT

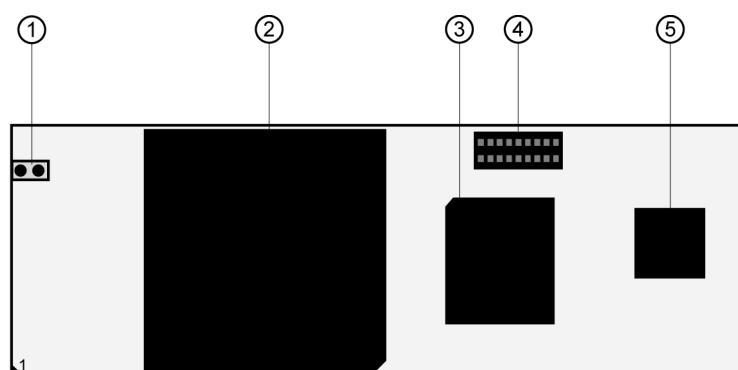

top view

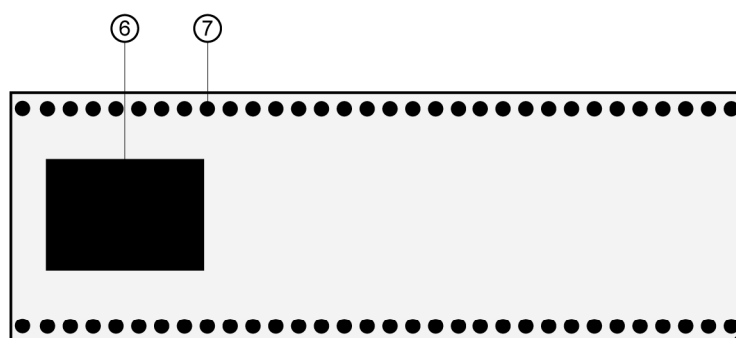

bottom view

- ① JP1 - RCM jumper
- ② IC1 - Vortex86SX MCU
- ③ IC2 - DDR2 RAM
- ④ J2 - ISP/Test connector
- ⑤ IC3 - USB NAND Flash controller
- ⑥ IC4 - NAND Flash memory
- ⑦ J1 - DIL-64 socket

Figure 2: Board layout DIL/NetPC DNP/2486

3 PINOUTS

3.1 DIL-64 Connector – J1 (1. Part)

Pin	Name	Group	Function
1	PA0	PIO	Parallel I/O, Port A, Bit 0
2	PA1	PIO	Parallel I/O, Port A, Bit 1
3	PA2	PIO	Parallel I/O, Port A, Bit 2
4	PA3	PIO	Parallel I/O, Port A, Bit 3
5	PA4	PIO	Parallel I/O, Port A, Bit 4
6	PA5	PIO	Parallel I/O, Port A, Bit 5
7	PA6	PIO	Parallel I/O, Port A, Bit 6
8	PA7	PIO	Parallel I/O, Port A, Bit 7
9	PB0	PIO	Parallel I/O, Port B, Bit 0
10	PB1	PIO	Parallel I/O, Port B, Bit 1
11	PB2	PIO	Parallel I/O, Port B, Bit 2
12	PB3	PIO	Parallel I/O, Port B, Bit 3
13	PB4	PIO	Parallel I/O, Port B, Bit 4
14	PB5	PIO	Parallel I/O, Port B, Bit 5
15	PB6	PIO	Parallel I/O, Port B, Bit 6
16	PB7	PIO	Parallel I/O, Port B, Bit 7
17	PC0	PIO	Parallel I/O, Port C, Bit 0 (Alternate Function: SPI Chip Select SPICS)
18	PC1	PIO	Parallel I/O, Port C, Bit 1 (Alternate Function: SPI Clock SPICLK)
19	PC2	PIO	Parallel I/O, Port C, Bit 2 (Alternate Function: SPI Master Out Slave In, MOSI = SPI Data Output)
20	PC3	PIO	Parallel I/O, Port C, Bit 3 (Alternate Function: SPI Master In Slave Out, MISO = SPI Data Input)
21	RXD1	SIO	COM1 Serial Port, RXD Pin
22	TXD1	SIO	COM1 Serial Port, TXD Pin
23	CTS1	SIO	COM1 Serial Port, CTS Pin
24	RTS1	SIO	COM1 Serial Port, RTS Pin
25	DCD1	SIO	COM1 Serial Port, DCD Pin
26	DSR1	SIO	COM1 Serial Port, DSR Pin
27	DTR1	SIO	COM1 Serial Port, DTR Pin
28	RI1	SIO	COM1 Serial Port, RI Pin
29	RESIN	RESET	RESET Input
30	TX+	LAN	10BASE-T/100BASE-TX Ethernet Interface, TX+ Pin
31	TX-	LAN	10BASE-T/100BASE-TX Ethernet Interface, TX- Pin
32	GND	---	Ground

Table 2: Pinout DIL-64 connector – pin 1 to 32

3.2 DIL-64 Connector – J1 (2. Part)

Pin	Name	Group	Function
33	RX+	LAN	10BASE-T/100BASE-TX Ethernet Interface, RX+ Pin
34	RX-	LAN	10BASE-T/100BASE-TX Ethernet Interface, RX- Pin
35	RESOUT	RESET	RESET Output
36	VBAT	PSP*	Real Time Clock Battery Input
37	CLKOUT	PSP*	Clock Output
38	TXD2	PSP*	COM2 Serial Port, TXD Pin
39	RXD2	PSP*	COM2 Serial Port, RXD Pin
40	HDMA	PSP*	USB Host Port- (Interrupt Input on other DIL/NetPCs, please see note 1)
41	HDPA	PSP*	USB Host Port+ (Interrupt Input on other DIL/NetPCs, please see note 1)
42	INT3	PSP*	Interrupt Input 3
43	INT2	PSP*	Interrupt Input 2
44	INT1	PSP*	Interrupt Input 1
45	CS4	PSP*	Chip Select Output 4 (x86 I/O Address Range 0x130 - 0x13F)
46	CS3	PSP*	Chip Select Output 3 (x86 I/O Address Range 0x120 - 0x12F)
47	CS2	PSP*	Chip Select Output 2 (x86 I/O Address Range 0x110 - 0x11F)
48	CS1	PSP*	Chip Select Output 1 (x86 I/O Address Range 0x100 - 0x10F)
49	RDY	PSP*	External Ready Input
50	RD	PSP*	Read Signal, Expansion Bus
51	WR	PSP*	Write Signal, Expansion Bus
52	SA3	PSP*	Expansion Bus, Address Bit 3
53	SA2	PSP*	Expansion Bus, Address Bit 2
54	SA1	PSP*	Expansion Bus, Address Bit 1
55	SA0	PSP*	Expansion Bus, Address Bit 0
56	SD7	PSP*	Expansion Bus, Data Bit 7
57	SD6	PSP*	Expansion Bus, Data Bit 6
58	SD5	PSP*	Expansion Bus, Data Bit 5
59	SD4	PSP*	Expansion Bus, Data Bit 4
60	SD3	PSP*	Expansion Bus, Data Bit 3
61	SD2	PSP*	Expansion Bus, Data Bit 2
62	SD1	PSP*	Expansion Bus, Data Bit 1
63	SD0	PSP*	Expansion Bus, Data Bit 0
64	VCC	---	3.3 Volt Power Input

Table 3: Pinout DIL-64 connector – pin 33 to 64

* **Please note:** Some pins are called "Product Specific Pins (PSP)". Other members of the DIL/NetPC family will differ with these pins from the DNP/2486. All other pins will have the same primary functions. The DNP/2486 alternate functions (Pin 1 to Pin 20) are Vortex86SX-specific.

Note 1: The DNP/2486 USB 2.0 Host Interface is available over the DIL-64 pins 40 & 41. These two pins are normally the interrupt inputs 4 and 5 within the DIL/NetPC DIL-64 pin-out. If your applications needs five interrupt input lines to be compatible with other DIL/NetPCs please contact the SSV sales or technical support staff.

3.3 ISP/Test Connector – J2

Pin	Name	Function
1	VCC	3.3 VDC
2	GND	Ground
3	---	Reserved
4	FS1	Reserved for Factory Setup
5	FS2	Reserved for Factory Setup
6	---	Reserved
7	FS3	Reserved for Factory Setup
8	FS4	Reserved for Factory Setup
9	---	Reserved
10	FS5	Reserved for Factory Setup
11	FS6	Reserved for Factory Setup
12	---	Reserved
13	FS7	Reserved for Factory Setup
14	---	Reserved
15	---	Reserved
16	---	Reserved
17	FS8	Reserved for Factory Setup
18	VCC	3.3 VDC

Table 4: Pinout ISP/Test connector



3.4 RCM Jumper – JP1

The **RCM (Remote Console Mode)** offers the possibility to control the DNP/2486 via a terminal emulation program over the UART-based serial port COM1 (serial-based CLI = Command Line Interface).

Please note: The default setting of the RCM jumper is set (Enable Remote Console Mode). This mode is checked by the AMI Basic I/O System (BIOS). With RCM jumper set, it is possible to control a DOS O/S over COM1. DOS I/O goes direct over the AMI BIOS I/O functions.

To disable RCM remove the jumper cap of the RCM jumper. This frees UART based serial port COM1 for application usage.

RCM jumper	Function
Not set	Disable Remote Console Mode
Set (default)	Enable Remote Console Mode

Table 5: RCM jumper settings

4 MEMORY MAP

4.1 System Memory Map

Physical Address Range	Description	Access Format	Type
0x0000.0000 - 0x000F.FFFF	1 MByte DOS/BIOS Area	16-bit MEM R/W	MEM
0x0010.0000 - 0x03FF.FFFF	63 MByte Main Memory	16-bit MEM R/W	MEM

Table 6: System memory map of DIL/NetPC DNP/2486

4.2 System I/O Map

Physical Address Range	Description	Access Format	Type
0x000 - 0x3FF	IO Address Space	*	*
0x78	PIO Port A Data Register	8-bit IO R/W	*
0x79	PIO Port B Data Register	8-bit IO R/W	*
0x7B	PIO Port C Data Register	8-bit IO R/W	*
0x98	PIO Port A Direction Register	8-bit IO R/W	*
0x99	PIO Port B Direction Register	8-bit IO R/W	*
0x9B	PIO Port C Direction Register	8-bit IO R/W	*
0x100 - 0x10F	Chip Select Signal CS1#	8-bit IO R/W	GPCS1
0x110 - 0x11F	Chip Select Signal CS2#	8-bit IO R/W	GPCS1
0x120 - 0x12F	Chip Select Signal CS3#	8-bit IO R/W	GPCS1
0x130 - 0x13F	Chip Select Signal CS4#	8-bit IO R/W	GPCS1

Table 7: External I/O map of DIL/NetPC DNP/2486

* Refer to Vortex86SX manual.

5 MECHANICAL DIMENSIONS

All length dimensions have a tolerance of 0.5 mm.

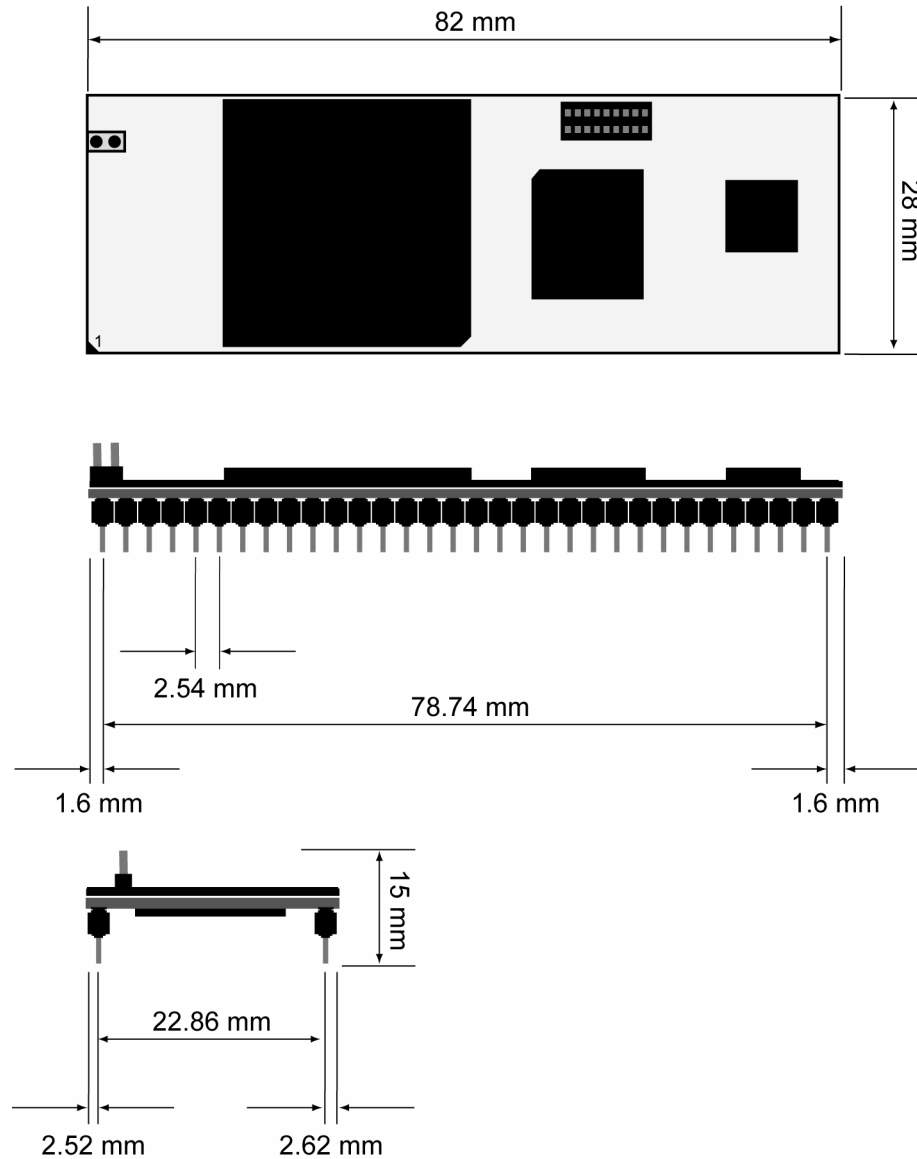

Figure 3: Mechanical dimensions of DIL/NetPC DNP/2486

6 HELPFUL LITERATURE

- Vortex86SX documents: <http://www.vortex86sx.com>
- Vortex86SX Brief Datasheet (available on DNP/2486 starter kit CD-ROM)
- Vortex86SX Detail Datasheet (available on DNP/2486 starter kit CD-ROM)

CONTACT

SSV Embedded Systems

Heisterbergallee 72

D-30453 Hannover

Phone: +49 (0)511/40 000-0

Fax: +49 (0)511/40 000-40

E-mail: sales@ist1.de

Internet: www.ssv-embedded.de

Support: www.ssv-comm.de/forum

For actual information about the DIL/NetPC DNP/2486 visit us at www.dilnetpc.com.

DOCUMENT HISTORY

Revision	Date	Remarks	Name
1.0	2008-07-15	First version	WBU
1.1	2008-07-16	Change within Helpful Literature and Memory Map	KDW
1.2	2008-08-12	Change within system I/O mapping table	KDW
1.3	2009-01-15	Change within chapter 3.3	WBU

The content of this document can change any time without announcement. There is taken over no guarantee for the accuracy of the statements. The user assumes the entire risk as to the accuracy and the use of this document. Information in this document is provided 'as is' without warranty of any kind. Some names within this document can be trademarks of their respective holders.

© 2009 SSV EMBEDDED SYSTEMS. All rights reserved.